



2009 *International Application Guide* • Volume 8 • Issue 2 • 2-18-09



L955 MILLENNIUM SERIES™

L955 Millennium Series™ Models

L955SE3143IB

Useable Platform:
31" x 43" (79 cm x 109 cm)

L955SE3147IB

Useable Platform:
31" x 47" (79 cm x 119 cm)

Explanations of abbreviations: L955 SE 31 43 IB

SE = Side Entry Platform

31 = 31" (79 cm) Clear Platform Width

43 = 43" (109 cm) Clear Platform Length

IB = Inboard Barrier

L955SE3151IB

Useable Platform:
31" x 51" (79 cm x 130 cm)

L955SE3455IB

Useable Platform:
34" x 55" (86 cm x 140 cm)

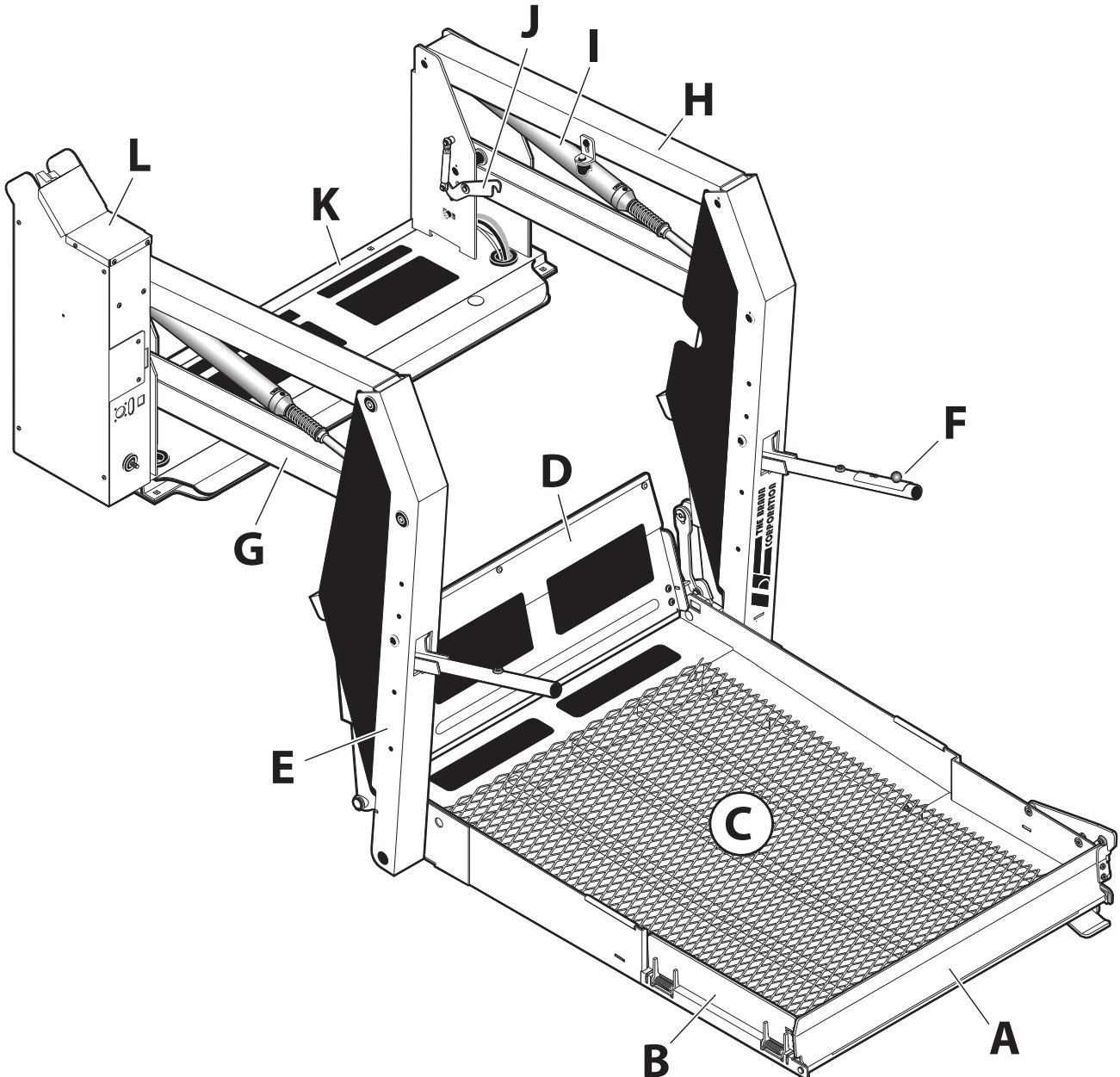

A - Automatic Outboard Barrier	G - Bottom Parallel Arms (2)
B - Side Entry (SE)	H - Top Parallel Arms (2)
C - Platform	I - Cylinder (2)
D - Inboard Barrier (IB)	J - Lift-Tite Latch
E - Vertical Arms (2)	K - Base Plate
F - Handrails (2), with Up/Down Switch	L - Pump Module

L955 Millennium Series™ Dimensions

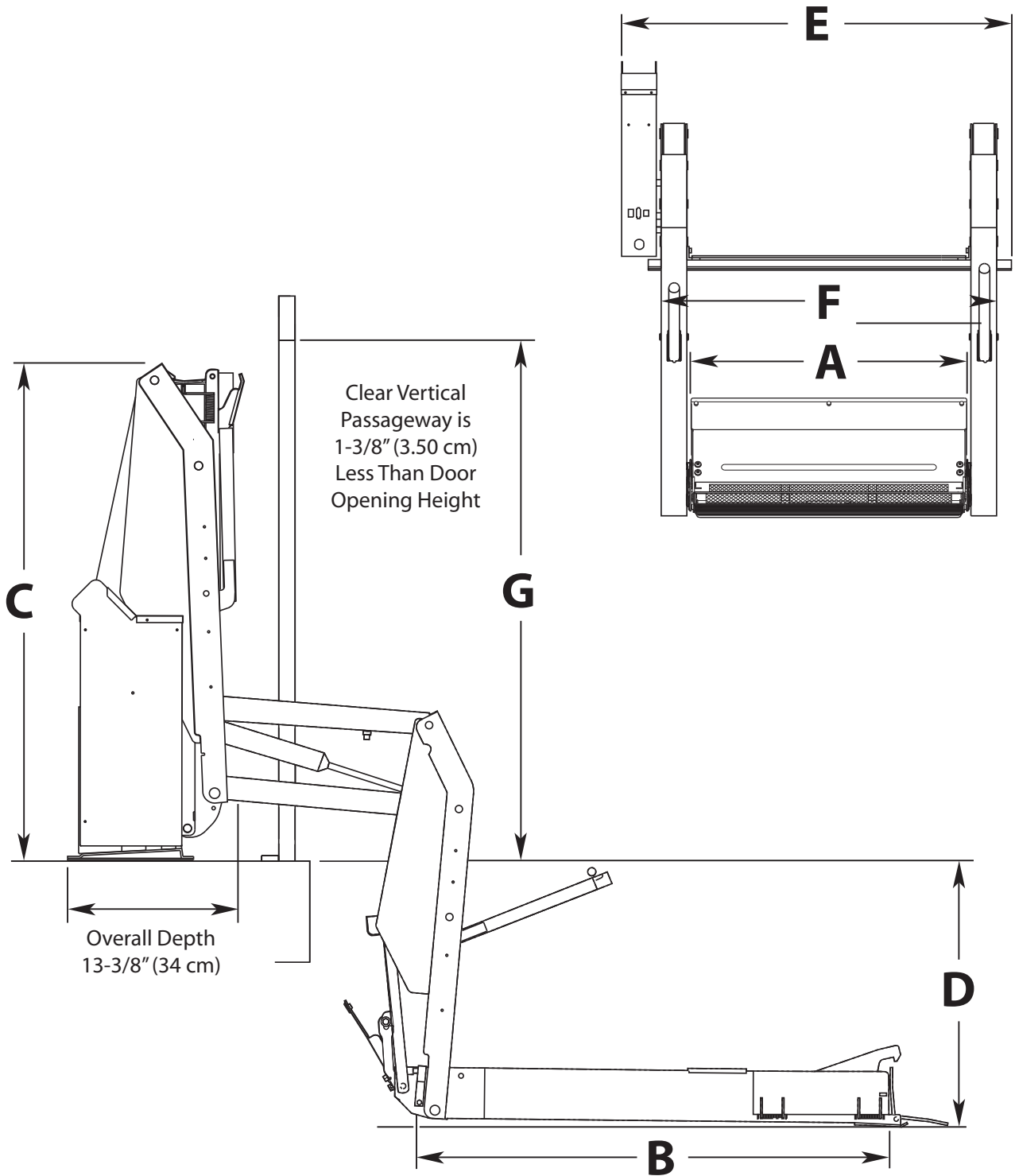

All dimensions are for reference only.

L955 Millennium Series™			A	B	C	D	E	F	G
Lift Model Number	Operation		Clear Platform Width	Clear Platform Length	Overall Lift Height	Max. Floor to Ground	Overall Lift Width	Min. Clear Door Opening Width	Min. Clear Door Opening Height
	User	Attdt.							
L955SE3143IB	X	X	31"(79cm)	43"(109cm)	47.5"(121cm)	42"(107cm)	46"(117cm)	40"(102cm)	47"(119cm)
L955SE3147IB	X	X	31"(79cm)	47"(119cm)	51.5"(131cm)	42"(107cm)	46"(117cm)	40"(102cm)	51"(130cm)
L955SE3151IB	X	X	31"(79cm)	51"(130cm)	55.5"(141cm)	42"(107cm)	46"(117cm)	40"(102cm)	55"(140cm)
L955SE3455IB	X	X	34"(86cm)	55"(140cm)	59.5"(151cm)	42"(107cm)	49"(124cm)	43"(109cm)	59"(150cm)

L955 Millennium Series™ Specifications

General Function: Electrohydraulic, power up/gravity down operation

Operation: Hydraulic pump with two lifting cylinders and one outboard barrier cylinder

Control: Module mounted switches, handrail Up/Down switch, optional hand-held control and remote

Hydraulic: Pressure Max. 2,495 psi (172 bar), Fluid is Univis HVI 26, reservoir is .33 gal (1.25 L)

Construction: Steel structure with powder coat finish

Lift Weight: 340 lbs (154 kg) - 355 lbs (161 kg) (depending on lift model)

Lifting Capacity: 800 lbs (363 kg)

Operating Temperature: 19°F to 149°F (-7°C to 65°C)

Power Supply: 12V DC or 24V DC

Current Consumption: Max. 70A (12V), Max. 35A (24V)



L955 Millennium Series™ Accessories



◀ **62400-000** Side Swing In-Door Operators



23170A Side Slide Door Operator ▶



15606A
Hand-Held
Control Station Kit

Included at no charge when specified on a lift without door operators. Controls lift functions only.



34972K
Six-Touch Remote
Control System

(North American Frequency)
Controls all lift functions as well as door operators (if so equipped)

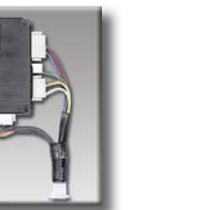

34352
Extra Transmitter
for Six-Touch



26230A
Threshold
Warning Kit

L955 Millennium Series™ Features

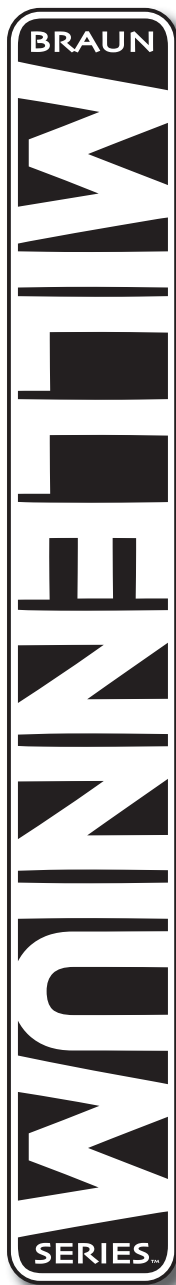

- fully automatic lift, operated by the wheelchair occupant or an attendant
- parallel arm lift with hydraulic cylinders
- color-coded rocker switches integrated on the lift
- additional up/down switch mounted on the handrail
- optional operation by hand-held control box
- optional operation by remote control
- side or rear door application
- miscellaneous platform widths and lengths
- dual handrails for security and convenience
- side entry (SE) platform provides easier access in tight parking situations
- hydraulic automatic outboard barrier that will be in the fully up position before the platform leaves the ground
- mechanical inboard barrier (IB models), ensuring extra safety for the wheelchair occupant
- bridging feature permits the wheelchair user to board the lift from sidewalks or inclines
- integrated back-up pump
- designed for use with automatic door operators
- equipped with an adjustable anti-rattle feature to avoid unpleasant noise in the vehicle during transit
- durable high-gloss powder coated finish
- Lift-Tite system stows the lift platform securely while the vehicle is in transit
- optional threshold warning kit - with the lift away from floor level, an alarm will sound when passengers approach the doorway



www.braunability.com/international

ISO 9001:2000

631 West 11th Street, Winamac, IN 46996, USA Phone: +1 574 946 6153 Fax: +1 574 946 4670